

# Scooter Dolly

---



## Scooter Dolly Operating Instructions

### English Version

# Scooter Dolly

CE			Issue Date: 2013/01

## Index of Contents

<b>1. Information about the Equipment</b> .....	<b>4</b>
1.1 Scope of Supply .....	4
1.2 Responsibilities of the Manufacturer / EC Declaration of Conformity .....	5
1.3 Responsibilities of the operator .....	6
1.4 Exploded drawing with numbering .....	6
1.5 External Interfaces.....	7
1.6 Legal information .....	7
<b>2. Operating Instructions</b> .....	<b>7</b>
2.1 How to correctly understand the operating instructions .....	8
2.1.1 Signs on the equipment .....	8
2.1.2 Signs in these operating instructions .....	8
2.2 Service Address .....	9
<b>3. Safety Information</b> .....	<b>10</b>
3.1 Manufacturer's General Safety Advice .....	10
3.2 General Safety Advice for Use .....	10
3.3 General Safety Advice for Inspection .....	11
3.4 Correct and Proper Use of the Scooter Dolly .....	11
3.4.1 Suspended Installation of the Scooter Dolly .....	11
3.5 Requirements Placed on Personnel .....	12
3.6 Safety Related Environment Conditions.....	12
3.7 Possible Misuse.....	12
3.8 Other Risks and Protective Measures .....	13
<b>4. Technical Information</b> .....	<b>13</b>
<b>5. Assembly and Operation</b> .....	<b>14</b>
5.1 Main Components .....	14
5.2 Optional Accessories.....	15
5.3 Delivery and Assembly .....	18
5.3.1 Assembly of the Track Connectors on the Tripod .....	18
5.4 Assembly of the Feet.....	21
5.5 Assembly of the Ball Adapter 75 / 100mm .....	22
5.6 Disassembly of the Clamping Ring .....	23
5.7 Assembly of the Ball Adapter 100mm/ 150mm/ Mitchell Adapter .....	23
5.8 Assembly of the Track on the Euro adapter (for example Dolly Magnum) .....	24
5.9 Assembly of the Push Rod .....	24
5.10 Cleaning the Tracks.....	25
<b>6. List of Risks Considered and Identified not to be Relevant</b> .....	<b>26</b>

## 1. Information about the Equipment

### 1.1 Scope of Supply

1.	Scooter Dolly with clamping ring 80mm
2.	2x Track Connectors
3.	2x Base plates with levelling feet, scratch protection and self-locking nuts
4.	6x Fixing screws for the feet M6x20
5.	2x Grub screws M10 for assembly under the track connectors for tripod use
6.	2x Plastic star handles
7.	Transport case complete
8.	1 x Set Allen keys
9.	1 x Operating instructions
10.	
11.	
12.	

Packed on (Date):

Signature:

---



---

## **1.2 Responsibilities of the Manufacturer / EC Declaration of Conformity**

### **EC Declaration of Conformity in accordance with the Machinery Directive 2006/42/EG Appendix II 1.A**

The manufacturer / distribution company

MovieTech AG  
Martin-Kollar-Str. 9  
D-81829 München

Herewith declares that the following product

Product Designation: Scooter Dolly  
Brand: MovieTech  
Serial Number:  
Type Designation: Dolly product  
Description: The Scooter Dolly is a product developed for the photography and film industries to enable sliding camera moves.

meets all relevant provisions of the above directive as well as other directives applied (see below) - including valid changes at the time of this declaration.

The following harmonized standards have been applied:

EN ISO 12100-1:2003 Safety of Machinery - Basic Concepts, General Principles for Design - Part 1: Basic Terminology, Methodology (ISO 12100-1:2003)

EN ISO 12100-2:2003 Safety of Machinery - Basic Concepts, General Principles for Design - Part 2: Technical Principles (ISO 12100-2:2003)

EN ISO 14121-1:2007 Safety of Machinery – Risk Assessment - Part 1: Principles (ISO 14121-1:2007)

Name and address of the person authorized to compile the technical documentation:

Mr. F. Strassmann

Location: Munich

Date: 21.01.2013

### 1.3 Responsibilities of the operator

#### Rules for overhauling

Overhauling of the Scooter dolly is allowed only by MovieTech AG or authorized contracting partner.

#### Disposal

The Scooter Dolly may not be disposed of in household waste. It must be disposed of at a collection point (please obtain information from your local community) or by your dealer / manufacturer.

This ensures environmentally friendly disposal.

#### Care

It is recommended to clean the Scooter Dolly with a damp, clean cloth if it is dirty. Avoid caustic or aggressive cleaning additives. Regular cleaning of the track profile (top and bottom) as well as the track rollers is necessary for optimum smooth running.

### 1.4 Exploded drawing with numbering

**NOTE** Please use the part numbers given when ordering spare parts!  
**Scooter Dolly**

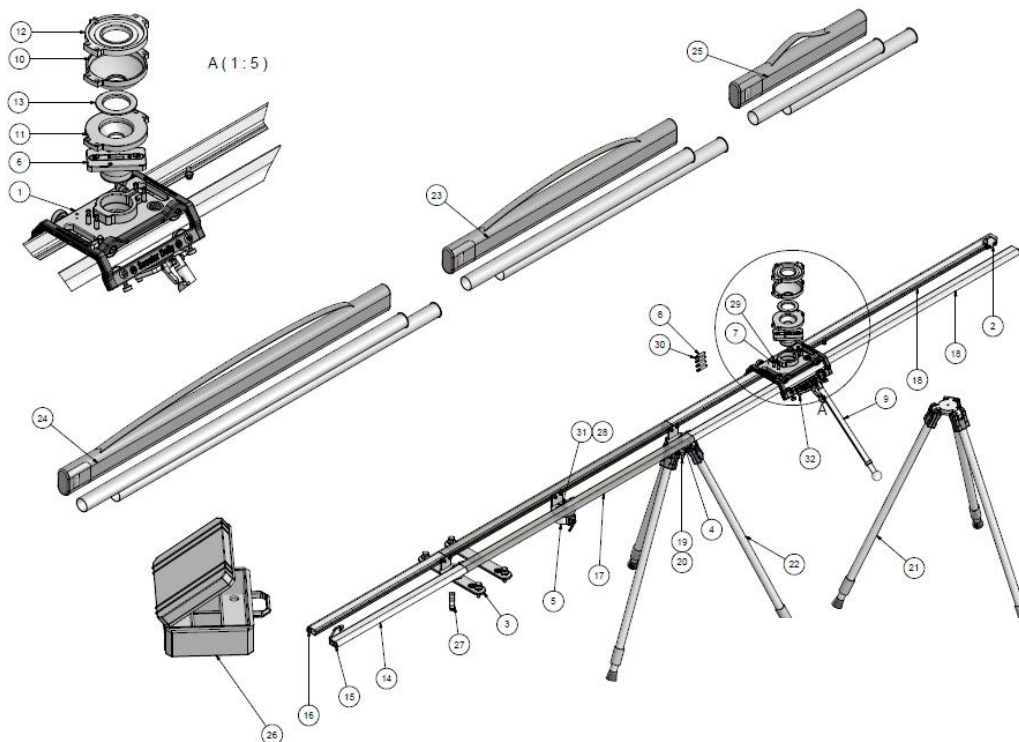

## 1.5 External Interfaces

The Scooter Dolly is self-contained.

## 1.6 Legal information

The limit values specified by the manufacturer must be absolutely complied with. Any exceeding is to be avoided in all circumstances.

In the event of accidents because of negligent or improper use, the manufacturer can not be held responsible for any damage or injuries whatsoever. It is imperative that the sequence of assembly and disassembly specified in the operating instructions is followed.

### **For the maintenance of the product, original spare parts are to be used exclusively.**

Accessories from other manufacturers may not restrict either the application or safe use of the Scooter Dolly!

The people entrusted with the use of the Scooter Dolly must have read and understood the original operating instructions of the manufacturer. The manufacturer should be contacted for questions concerning safe use. The contact person can be found in these operating instructions or on the website under [www.movietech.de](http://www.movietech.de).

### **Useful life of the equipment:**

The useful life is limited by component wear and component fatigue. The use life is therefore dependant upon the frequency of use and the environmental conditions to which the Scooter Dolly is subjected.

## 2. Operating Instructions

We thank you for choosing the Scooter Dolly and placing your trust in us.

The Scooter Dolly allows sliding camera moves in the horizontal plane.

We wish you lots of pleasure and success with your new MovieTech Scooter Dolly!

### **Your Scooter Dolly has the following key features:**

- extendable tracks
- short assembly and disassembly times
- low transport weight 4.7 kg
- adjustable wheels
- adaptable for tripod and base plate with levelling feet

Please read the operating instructions through carefully before you use your new equipment for the first time. They contain everything you need to know for its use in order to avoid injuries to people or damage to property.



Please read carefully all safety advices in these operating instructions.

Please keep these operating instructions safely. Hand these operating instructions over to the new owner if you sell the equipment or otherwise dispose of it.





Please inform further users of the necessity of reading and understanding the operation instructions before the first use.

## 2.1 How to correctly understand the operating instructions



### 2.1.1 Signs on the equipment

	<p><b>CE Mark:</b></p> <p>This sign means that your equipment meets the safety requirements of the applicable EU directives</p>
	<p><b>Rubbish Bin:</b></p> <p>This sign means that the equipment may only be disposed of at a local waste disposal centre</p>

### 2.1.2 Signs in these operating instructions

Sign	Meaning
	<p>Makes you aware of the use and effect of safety information.</p>
 <b>WARNING</b>	<p>Makes you aware of a dangerous situations which could lead to serious injury or death if it is not avoided.</p>
 <b>ATTENTION</b>	<p>Makes you aware of a dangerous situation which could lead to slight or medium injuries if it is not avoided.</p>
<b>NOTE</b>	<p>Makes you aware of possible property damage and other important information in connection with your equipment.</p>
 <b>Foot protection</b>	<p><b>Safety shoes:</b></p> <p>Mandatory sign in accordance with ANSI (in accordance with Z 535.3 - 2007)</p> <p>Meaning: Foot protection</p>

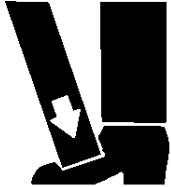

 <p><b>Walking on this surface is forbidden</b></p>	<p><b>Walking on this surface is forbidden</b></p> <p>Mandatory sign in accordance with ASR A1.3 Attachment 1 (to date BGV A8, previously VBG 125), DIN 4844-2 :2001-02 and DIN 4844-2/A1: 2004-05</p> <p>Meaning: Walking on this surface is forbidden</p>
 <p><b>Fall down / drop</b></p>	<p><b>Falling objects / downward movement</b></p> <p>Warning sign in accordance with ANSI (in accordance with Z 535.3 - 2007)</p> <p>Meaning: Falling objects / downward movement – Danger to the feet</p>
 <p><b>Crush Hazard</b></p> <p>bruise / crush</p>	<p><b>Crush Hazard:</b></p> <p>Warning sign in accordance with ANSI (in accordance with Z 535.3 - 2007)</p> <p>Meaning: Crush hazard – Danger to the hands</p>

## 2.2 Service Address

### MovieTech AG

Martin-Kollar-Str. 9

D-81829 München

E-Mail: [info@movietech.de](mailto:info@movietech.de)

[www.movietech.de](http://www.movietech.de)

Tel.: +49 (0) 89 43 68 91 3

### **3. Safety Information**

#### **3.1 Manufacturer's General Safety Advice**

- Only qualified people must be given the job of assembly, disassembly and operation of dollies. Authorization must be given in writing.
- Be aware of possible pinch points when assembling and disassembling, and during operation (please see the chapter "Assembly" and special warning notices for each phase of operation). Warning signs on the product and in the operating instructions must be observed!
- Safety gloves should be worn to avoid injury during assembly and disassembly.
- Electrical equipment such as, for example, monitors, must always be protected against moisture and dampness.

#### **3.2 General Safety Advice for Use**

- Please observe the advice for the use of a maximum camera weight of 30 kg, warnings on the equipment, special advice on stability and safe use.
- Do not leave the assembled Scooter Dolly unattended. Secure it against unauthorized use.
- Due to the danger of a lightning strike, cease operating in the event of an approaching thunderstorm.
- The Scooter Dolly may be used in ambient temperatures from -5 to +40°C.
- The Scooter Dolly is suitable for studio and limited outdoor use. Sandy, dusty, salty and wet environments should be avoided as location sites.
- The slamming of the dolly, especially the wheels against objects and obstacles with sharp edges should be avoided because of the possible damage to the materials. Damaged wheels and other safety relevant components must be replaced and can be obtained from the manufacturer.

### 3.3 General Safety Advice for Inspection

- Safety must be checked through visual and functional checks before every use (in accordance with DIN15999)
- Especially the following criteria should be considered
  - unusual noise or movement,
  - deformation (for example, bending, twisting),
  - damage (for example, cracks, corrosion),
  - missing parts (for example safety split pins, fasteners)
  - un-round movement of the wheels (for example through standing for a long time or contamination of the running surface)
  - grinding of the brakes (for example contamination of the braking surface, locked brakes when moving the dolly)
- In the event of any changes in shape or damage, the manufacturer must be contacted!
- Please note all other safety advice in the following chapters!

### 3.4 Correct and Proper Use of the Scooter Dolly

The Scooter Dolly may only be used in accordance with its “**Correct and Proper Use**”. The Scooter Dolly is intended for horizontal camera travel. The camera must have a weight <30kg. The weight of a tilting or swivel head or similar or an alternative camera fixing must also be considered.

#### Attention!

**The dolly must always be evenly loaded! Unbalanced loading impairs smooth running. When using side or similar adapters, for example, a counter weight must be used for balance.**

The dolly must be used on the specially designed track profile (MasterTrack Profile from MovieTech in the width defined by the special track adapters).

#### 3.4.1 Suspended Installation of the Scooter Dolly

Suspended installation of the Scooter Dolly is possible up to a payload of 15 kg!



**WARNING**

The dolly must be protected from falling off the tracks by cables or additional sufficient, adequate safety precautions. Fitted peripheral equipment such as cameras, monitor and other fittings must be protected from falling by additional safety equipment. With suspended installation of the Scooter Dolly, the operating area beneath the Scooter Dolly must be kept clear and a sufficient, compulsory distance kept at the sides of at least 2m on either side below the track.

The use of the dolly suspended or standing above people is forbidden!

The liability of the manufacturer is expressly excluded in the event of the violation of the safety rules!

### 3.5 Requirements Placed on Personnel

The operator of the dolly should be able to control the camera picture as well as the operating radius of the Scooter Dolly. The use of the Scooter Dolly must always be considered with respect to the relevant safety aspects. The responsibility for safe use lies with the user. Distances between camera and objects must always be correctly judged with respect to safety to avoid accidents and injuries. Responsible handling of the product in the respective environment is required. The user must have noticed and have understood the safety related aspects of the operation through the operating instructions. .

#### General Safety at Work Advice:

In operating the Scooter Dolly, the danger of the head colliding with a performer arises.



Access to the inside of the action radius of the Scooter Dolly is only allowed for the operator!

The presence of people beneath the travel tracks is not allowed out of safety reasons!

Walking on  
this surface  
is forbidden

### 3.6 Safety Related Environment Conditions

The Scooter Dolly is suitable for use in the following environmental conditions:  
Studio and limited outdoor operation.

Sandy, dusty, salty and wet environments should be avoided as location sites!

Environments with heavy rain, snowfall and strong or squally winds must be avoided!

The base must be flat and of a stable composition suitable for the total weight of the Dolly.

Always remember that the pressure on the floor of each individual tripod leg under load – when the Scooter Dolly is loaded is considerably multiplied.

Avoid the setting up of the Scooter Dolly on snow, sand and boggy ground.

### 3.7 Possible Misuse

The following uses of the Scooter Dolly are not allowed and **must be avoided**:

- The use of cameras with a total weight of over 30 kg
- The use of the Scooter Dolly without tracks
- The use of the Scooter Dolly for supporting lighting systems
- The use of the Scooter Dolly in sandy environments
- Use under water
- The use of the dolly on the track **without** end stops!
- **The use of the dolly on dirty track profiles!**
- **The use of the dolly with dirty wheels!**

### 3.8 Other Risks and Protective Measures

#### Transport / Storage:

- When transporting the Scooter Dolly, it must be ensured that no point loads are put on any of the individual parts.
- The dolly must be stored in a dry room.
- The dolly must not be stored in direct sunlight.
- The dolly must not be transported or shipped without the suitable supplied packing case.
- The dolly loaded with tracks on a tripod must not be moved. Before moving, all loads must always be removed in accordance with the operating instructions.

All accessories – external peripheral equipment – such as monitors must be disassembled before transport.

### 4. Technical Information

Packed dimensions case: 540 x 490 x 240 mm

Assembled dimensions: Track width (external) 220 mm

Weight: Dolly and standard accessory kit = 18.5kg

Dolly size: 336 x 302 mm

#### Materials Used:

Dolly platform: Aluminium

Wheel covers: Plastic

Screws and small parts: Stainless steel – aluminium – rubber compounds

## 5. Assembly and Operation

### 5.1 Main Components



Dolly with clamping ring 80mm  
 Clamping lever  
 Parking brake  
 Mudguard  
 Wheels, 2 of which with adjustment for the contact pressure on the track profile



2x Floor plates with levelling screws consisting of:  
 2x Base plates  
 2x Lock nuts  
 3x Fixing screws socket  
 2x Plastic sleeves for the levelling screws to prevent scratching



2x Tripod adapters consisting of:  
 4x Slot nuts with Allen screws  
 2x Tripod screws with star handles  
 1x Spirit level

1 x Set Allen keys



1 x Case with inlay

**Subject to technical changes, articles may be different to the picture.**

## 5.2 Optional Accessories



### Master Track Profile

Item No. 2500-2 Set / 0.90m

Item No. 2501-1 Set / 1.60m

Item No. 2502-1 Set / 2.30m

### Cover für MasterTrack Profile

Item No. 2207-8300 cover 0.90m

Item No. 2207-8100 cover 1.60m

Item No. 2207-8200 cover 2.30m



Item No. 2594-0 2595-0 Protective screw for track end piece MasterTrack

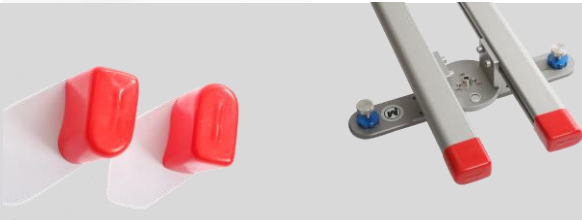

Item No. M5622 Protective cap red for MasterTrack



Item No. 2207-30 Set Base plate track connectors



Item No. 2207-20 Floor levelling plate



Item No. 2207-10 End stop  
1x

Subject to technical changes, articles may be different to the picture.



**Item No. 8321-0**  
Tripod 132X with 100mm ball adapter

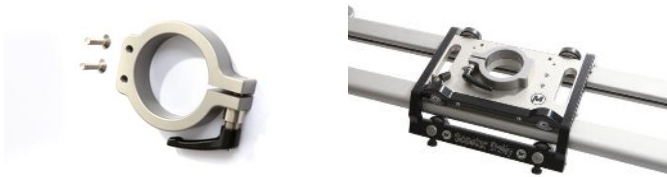

**Item No. 8530-2 Light bazooka-clamping ring**



**Item No. 8327-0 Ball adapter 75mm**  
Ball adapter insert 75mm with distance sleeves and screws



**Item No. 8328-0 Ball adapter 100mm**  
Ball adapter insert 100mm with distance sleeves and screws

**Item No. 8532-1 Ring insert 100 to 75mm**



**Item No. 2032-1 Set**  
Ball adapter insert 100mm with distance sleeves and screws



**Item No. 2031-3 Set**  
Ball adapter insert 150mm with distance sleeves and screws

Subject to technical changes, articles may be different to the picture.



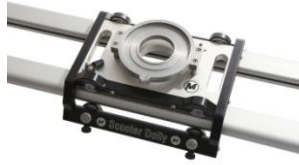

**Item No. 2041-10 Set**

Mitchell Base plate with distance sleeves and screws



**Item No. 2207-50**

Euromount adapter / track connector



**Item No. 2207-90**

Camera base plate / Euromount



**Item No. 2206-100 Push rod**



**Item No.xx Monitor bracket set**

Monitor bracket Set 3/8"-1/4" adapters ball joint

Subject to technical changes, articles may be different to the picture.

### 5.3 Delivery and Assembly

Please open the transport packing carefully.

Do not use any sharp tools such as cutters, scissors etc., which could lead to the damage of the transport bag or case or the tracks or the Dolly.

Please check the delivery contents. Compare the delivered goods with your delivery note!

In the event of missing parts, please contact your distributor.

In the event of damage to the packaging, the delivery company / forwarding agent must be informed without delay!

A later claim against the manufacturer because of damage to the goods from external foreign effects is expressly excluded!

#### 5.3.1 Assembly of the Track Connectors on the Tripod



**ATTENTION**

- **The tripod for the Scooter Dolly tracks may only be set on a stable, level and slip-free base. The load bearing capability of the floor or the bearing strength of the sub-floor must be known and have been reliably measured. The dolly must be so set up that its stability remains constantly during the operation.**
- **The tripod must be suitable for the maximum load. (Dolly, tracks, camera, accessories such as monitors etc.!) Observe the technical data of the manufacturer! People in the vicinity may be injured!**
- **Ensure that the tripod is always standing upright! Avoid it standing at an angle! Always ensure a firm base! In the event of an uncertain sub-floor the tripod legs must be supported with a solid base plate!**
- **Ensure that the tripod leg extension screws are always securely closed!**



bruise / crush

Warning sign in accordance with ANSI (in accordance with Z 535.3 - 2007)

Meaning: Crush hazard – Danger to the hands



**Crush Hazard**

In the space between the track connector and the tripod there is a crush hazard for hands and fingers!

Picture **01**

Pull out the tripod to the required height, set it down securely and level it.



Picture **02**

Securely re-tighten the tripod legs.



Picture **03**

Fit the track connector to the tripod.

Screw on the **M10** axle pin.



Picture **04**

Feed the screw through the opening in the tripod bowl. The support must be placed level and centrally on the bowl. Secure the track connector with the plain washer and the star nut.

**See Picture 5**



Picture **05**

Securely hand-tighten the star handle **B** up to the stop!



Picture **06**

Loosen the screws **A** in the slot nuts so far so that the track profile can be freely pushed in.

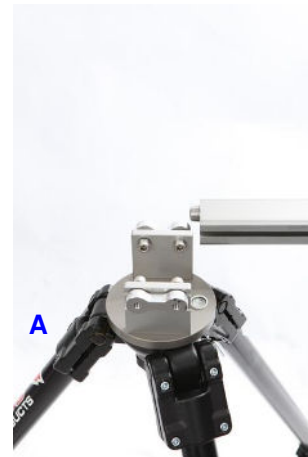



Picture **07**  
Align the tripods!



Picture **08**  
Position the track profile and tighten the slot nut screws with an Allen key.



Picture **09**  
Tracks must be horizontally levelled.



Picture **10**  
Levelling can be checked with the integral spirit level **1**.



Picture **11**  
Roll the Dolly on to the tracks



Picture **12**  
Feed the track end pieces in to the tracks. Open the slot nut screws for this. The rubber stops should always point in the direction of travel. Close the screws after positioning the end pieces.



Picture **13**  
Re-tighten the screws after positioning the end pieces!

**NOTE** Always securely tighten all screws on the track connector!

### 5.3.2 Brake

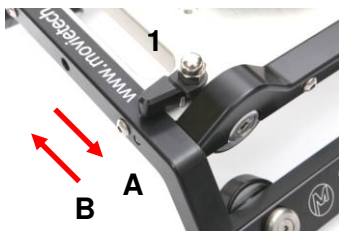

The brake (brake lever) is fitted with stops for the open position, **A**, and for the closed position, **B**!

**NOTE** The brake function is dependant upon the contact pressure of the wheels! The higher the contact pressure the greater the braking effect!

**Attention!** The dolly must only travel with an open brake to avoid damage to the brake rubber!

## 5.4 Assembly of the Feet



Picture 14  
Feet, screws,  
track connector

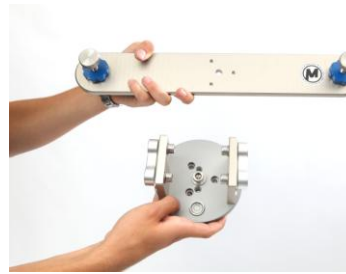

Picture 15  
Note the  
position of the  
holes



Picture 16  
Feed in 3 screws



Picture 17  
Tighten with an  
Allen key



Picture 18  
Finished  
assembly of the  
feet with track  
connector



Picture 19  
Open slot nut  
screws!  
Feed the track  
connector into  
the track profile.



Picture 20  
Set the track  
profiles parallel



Picture 21  
Finished  
assembly of the  
track with feet!



Picture 22  
Tighten the slot  
nut screws with  
an Allen key



Picture 23  
Levelling the  
base plate with  
the knurled  
screw



Picture **24**  
When the levelling is complete to stabilize, screw the locking nut (blue) against the base plate.



Picture **25**  
Open the contact pressure screw of the rollers so that the dolly can be lightly rolled on the track.



Picture **26**  
Roll the dolly onto the tracks!



Picture **27**  
Feed in the track end pieces! Sufficiently open the slot nut screws.



Picture **28**  
Securely fasten the screws with an Allen key.

## 5.5 Assembly of the Ball Adapter 75 / 100mm

Please open the locking lever! The ball adapter 75mm or 100mm with an external diameter of 80mm can be fed into opening up to the stop. Afterwards tighten the locking lever and check the ball adapter for firm seating.



Picture **29**  
For the assembly of the adapters 75 / 100 mm or the Euro coupling the locking ring must be open.



Picture **30**  
After the assembly of the ball adapter securely re-tighten the locking lever. The locking lever can be operated with a ratchet function.

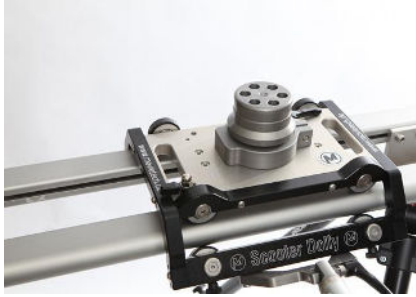

Picture **31**

Use of a double Euro item No. 2087-25 for the adaptation of accessories on a Euromount base!

**NOTE: The clamp of the Euromount has a diameter of 80mm! The assembly of remote heads from ABC-Products is possible on the basis of this clamping!**

## 5.6 Disassembly of the Clamping Ring

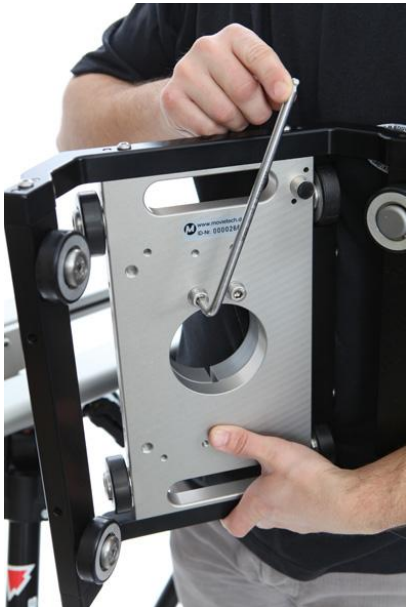

Picture **32**

Loosen the clamping ring screws with an Allen key and remove the clamping ring!



Picture **33**

After the removal of the screws the clamping ring can be detached.

## 5.7 Assembly of the Ball Adapter 100mm/ 150mm/ Mitchell Adapter



Picture **34**

Set the distance sleeves (4 of received in the scope of supply) in the intended recesses.



Picture **35**

Fit the 100mm, 150mm or Mitchell ball adapter!



Picture **36**  
 Insert and tighten the screws (4 received in scope of supply).

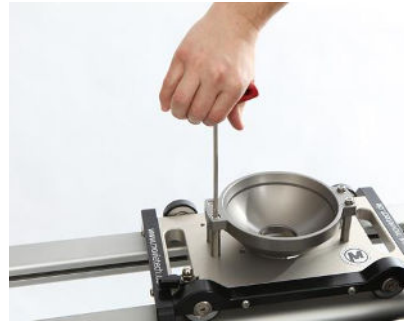

Picture **37**  
 Tighten the screws with an Allen key!

## 5.8 Assembly of the Track on the Euro adapter (for example Dolly Magnum)

**NOTE** The track length for this application should be limited to 1.60m!



Picture **38**  
 Feeding in of the track end pieces!  
 Sufficiently open the slot nut screws.



Picture **39**  
 Use of a lowboy adapter **A** (accessories) with an internal thread for assembly on the track connector

## 5.9 Assembly of the Push Rod



Picture **41**  
 Assembly of the push rod on the dolly frame

**Use for this the assembly screws (scope of supply push rod)**



### 5.10 Cleaning the Tracks

For smooth movements, clean and dust-free running surfaces and wheels are necessary!



Picture **42** Cleaning the track profile

**Important! Clean both the upper and lower sides of the profile!**

Do not use any corrosive cleaning fluids!

## 6. List of Risks Considered and Identified not to be Relevant

Hazard Sequence: Scissors (Mechanical Hazards)

Hazard Sequence: Cutting, Cutting-off (Mechanical Hazards)

Hazard Sequence: Grasping (Mechanical Hazards)

Hazard Sequence: Pulling-in, Catching (Mechanical Hazards)

Hazard Sequence: Puncture, Incision (Mechanical Hazards)

Hazard Sequence: Rubbing, Abrasion (Mechanical Hazards)

Hazard Sequence: Penetration of Fluids under Pressure (Mechanical Hazards)

Hazard Sequence: Suffocation (Mechanical Hazards)

Hazard Sequence: Slipping, Tripping, Falling (Mechanical Hazards)

Hazard Sequence: Burning (Electrical Hazards)

Hazard Sequence: Chemical Reaction (Electrical Hazards)

Hazard Sequence: Fatal Electric Shock (Electrical Hazards)

Hazard Sequence: Falling, being Flung Out (Electrical Hazards)

Hazard Sequence: Fire (Electrical Hazards)

Hazard Sequence: Spraying Out of Molten Parts (Electrical Hazards)

Hazard Sequence: (electric) Shock (Electrical Hazards)

Hazard Sequence: Effect on Medical Implants (Electrical Hazards)

Hazard Sequence: Burning (Thermal Hazards)

Hazard Sequence: Scalding (Thermal Hazards)

Hazard Sequence: Dehydration (Thermal Hazards)

Hazard Sequence: Discomfort (Thermal Hazards)

Hazard Sequence: Freezing (Thermal Hazards)

Hazard Sequence: Injury from Radiation from Heat Sources (Thermal Hazards)

Hazard Sequence: Discomfort (Noise Hazards)

Hazard Sequence: Unconsciousness (Noise Hazards)

Hazard Sequence: Loss of Balance (Noise Hazards)

Hazard Sequence: Permanent Loss of Hearing (Noise Hazards)

Hazard Sequence: Tinnitus (Buzzing in Ears) (Noise Hazards)

Hazard Sequence: Stress (Noise Hazards)

Hazard Sequence: All Other (for example mechanical, electrical) Problems as a Result of Disturbance to Voice Communication (Noise Hazards)

Hazard Sequence: Exhaustion (Noise Hazards)

Hazard Sequence: Diseases of the Lower Spine (Vibration Hazards)

Hazard Sequence: Joint Bone Damage (Vibration Hazards)

Hazard Sequence: Spinal Injury (Vibration Hazards)

Hazard Sequence: Discomfort (Vibration Hazards)

Hazard Sequence: Arterial Disease (Vibration Hazards)

Hazard Sequence: Neurological Disease (Vibration Hazards)

Hazard Sequence: Burning (Radiation Hazards)

Hazard Sequence: Effects on Reproductive Capability (Radiation Hazards)

Hazard Sequence: Genetic Mutation (Radiation Hazards)

Hazard Sequence: Headache, Sleeplessness etc. (Radiation Hazards)

Hazard Sequence: Eye and Skin Damage (Radiation Hazards)

Hazard Sequence: Breathing Difficulty, Suffocation (Material and Substance Hazards)

Hazard Sequence: Cancer (Material and Substance Hazards)

Hazard Sequence: Corrosion (Material and Substance Hazards)

Hazard Sequence: Effects on Reproductive Capability (Material and Substance Hazards)

Hazard Sequence: Genetic Mutation (Material and Substance Hazards)

Hazard Sequence: Explosion (Material and Substance Hazards)

Hazard Sequence: Fire (Material and Substance Hazards)

Hazard Sequence: Infection (Material and Substance Hazards)

Hazard Sequence: Sensitisation (Material and Substance Hazards)

Hazard Sequence: Poisoning (Material and Substance Hazards)



Hazard Sequence: Discomfiture (Ergonomic Hazards)

Hazard Sequence: Exhaustion (Ergonomic Hazards)

Hazard Sequence: Disturbance of the Muscular-skeletal System (Ergonomic Hazards)

Hazard Sequence: Stress (Ergonomic Hazards)

Hazard Sequence: all other (for example Mechanical, Electrical) Problems as a Result of Human Errors (Ergonomic Hazards)

Hazard Sequence: Burning (Hazards in Connection with the Location Environment of the Machine)

Hazard Sequence: Slight Illness (Hazards in Connection with the Location Environment of the Machine)

Hazard Sequence: Slipping, Falling (Hazards in Connection with the Location Environment of the Machine)

Hazard Sequence: All other Problems Arising as a Result of the Effects of the Hazard Sources of the Machine or the Components of the Machine (Hazards in Connection with the Location Environment of the Machine)

Hazard Sequence: Suffocation (Hazards in Connection with the Location Environment of the Machine)

Hazard Sequence: Combustible / Inflammable Materials (Hazards through Fire or Explosion)

Hazard Sequence: Explosive Atmosphere (Hazards through Fire or Explosion)

Hazard Sequence: Electrical Ignition Sources (Hazards through Fire or Explosion)

Hazard Sequence: Mechanical Ignition Sources (Hazards through Fire or Explosion)

Hazard Sequence: Other Ignition Sources (Hazards through Fire or Explosion)

Hazard Sequence: Breakdown / Disturbance of the Control System (Unexpected Start-up, Unexpected Overrun)

Hazard Sequence: Reconnecting the Energy Supply (Unexpected Start-up, Unexpected Overrun)

Hazard Sequence: External Influences on Electrical Components (Unexpected Start-up, Unexpected Overrun)

Hazard Sequence: Other Influences such as Gravity, Wind etc. (Unexpected Start-up, Unexpected Overrun)

Hazard Sequence: Software Errors (Unexpected Start-up, Unexpected Overrun)

Hazard Sequence: Operating Errors (Unexpected Start-up, Unexpected Overrun)

Hazard Sequence: Switching Off, EMERGENCY STOP

Hazard Sequence: Changes in the Revolution Speed

Hazard Sequence: Loss of the Energy Supply

Hazard Sequence: Loss of the Control or the Regulation Circuits

Hazard Sequence: Faulty Assembly

Hazard Sequence: Breakage During Operation

Hazard Sequence: Ejected Objects or Fluids

Hazard Sequence: Loss of Stability

Hazard Sequence: Slipping, Tripping or Falling of People



# MovieTech

[www.movietech.de](http://www.movietech.de)

Die MovieTech AG mit Hauptsitz in München und Tochtergesellschaften in Mailand und Prag produziert und vermarktet als einer der führenden Hersteller Produkte und Lösungen für die Film- und Fernsehindustrie.

Die Produktpalette von MovieTech konzentriert sich auf die Bereiche: Kamerakräne, Dollys, Lichtsysteme, Remote Heads und entsprechendes Zubehör.

Ziel der Movie Tech AG ist die Herstellung von professionellem Filmequipment, das die Arbeit der Anwender am Set oder im Studio wesentlich erleichtert und die Umsetzung der kreativen Ideen ermöglicht.

The MovieTech AG is based in Munich with subsidiaries in Milan and Prague. As one of the leading manufacturers in its field, it produces and markets products and solutions for the film industry.

The MovieTech product range concentrates on the areas of: Camera cranes, dollies, remote heads and corresponding accessories, as well as studio and stage techniques.

The MovieTech mission is the manufacture of professional film equipment that not simplifies the work of those using it on the set or in the studio, but also facilitates the implementation of creative ideas.



## MovieTech

[www.movietech.de](http://www.movietech.de)



Dollies – Cranes – Remote Heads



[www.abc-products.de](http://www.abc-products.de)



Steadycam systems – Light dollies – Light cranes



[www.mts-germany.com](http://www.mts-germany.com)



Pantographs – Hoists – Telescopes – Trolleys



[www.lastro.de](http://www.lastro.de)



Rail systems – Studio and stage engineering

**MovieTech AG** (Germany)

Martin-Kollar-Str. 9 • 81829 München • Tel: +49 (0)89-43 68 91 3 • Fax: +49 (0)89-43 68 91 55 • E-Mail: [info@movietech.de](mailto:info@movietech.de)

**MovieTech S.r.l.** (Italia)

Viale Edison 318 • 20099 Milano • Tel: +39 (0)2 22 47 00 43 • Fax: +39 (0)2 24 41 01 63 • E-Mail: [k.shore@movietech.de](mailto:k.shore@movietech.de)